



# Kiddie Pirate

In order to prevent the variety of problems which caused by incorrect operation, Please read the manual first before operating this machine and pay attention to the items marked in “note”.

Please keep this manual carefully for checking when needed.

## Summary

- ✧ Transportation, installation, safe operation of moving and operating methods and attentions;
- ✧ Installation and operation;
- ✧ Function adjustment;
- ✧ Maintenance;
- ✧ General troubleshooting and solutions;
- ✧ Main components diagram;
- ✧ Circuit connection diagram.

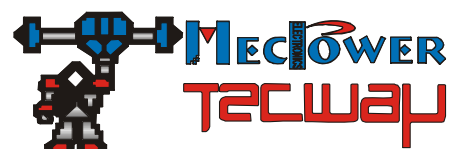

## Safety Attentions

- 1) Certain part of the game is with high voltage. Adjust the game by technician. Do not open the game door unless maintenance or parts replacement is required.
- 2) Please switch off the power before checking and maintenance.
- 3) Please switch off the power before opening the game door.
- 4) Fire extinguisher equipment must be nearby the game.

## Installation

The game must be located properly to avoid damages.

Improper Locations:

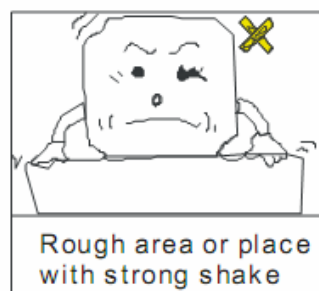
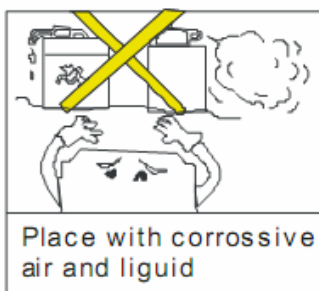
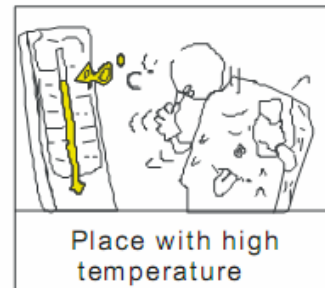
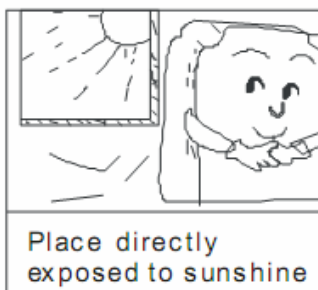

## Notes of Usage

- 1) The voltage range of the game should be 105V~115V or 215V~225V.  
The proper voltage should be 110V/220V. The specific voltage accords to the date plate on the back door of the game. The voltage must be correct; otherwise it would be difficult to repair the damage.
- 2) The plug must be plugged in tightly and keep the power cords not be too tight and damaged in order to prevent bodily injury, short-circuit and power leakage.
- 3) To put the machine to normal operating, please properly adjust the coin match and the game settings when use at the first time.
- 4) Please regularly check all the functions of the game when operate to prevent dysfunction.

## Notes of Maintenance

- 1) Be sure to check and maintenance the game regularly.
- 2) Switch off the power before replacing the parts of the game.
- 3) The parts for replacement should be the same model as the old one.
- 4) Please check the connection and voltage output after replacing the power supply.
- 5) The voltage range of the PCB should be 5.1V-5.4V.
- 6) Check whether the game has creepage and the voltage before repairing the PCB.

## Notes of Clean

- 1) Please use clean and soft colth to clean the game.
- 2) Prevent damaging the surface of the game, please do not use the following cleanser:
  - Alterative Cleanser;
  - Acidic Cleanser;
  - Insecticide, sterilized water, alcohol or other chemical cleanser.

## Notes of Moving and Shipping

- 1) Properly disassemble the game for necessary moving and shipping.
- 2) Prevent the game from hitting or being attrite during movement.
- 3) Protecting the case when move the game.

# CONTENT

1、	<b>GAME INTRODUCTION</b> .....	错误！未定义书签。
2、	<b>PLAYING TIPS AND OPERATIONS</b> .....	错误！未定义书签。
3、	<b>TECHNICAL PARAMETER</b> .....	错误！未定义书签。
4、	<b>MOVEMENT</b> .....	10
5、	<b>INSTALLATION</b> .....	11
5.1	CHOOSE THE LOCATION FOR INSTALLATION .....	错误！未定义书签。
5.2	CHECK AND SET BEFORE CONNECTING THE POWER...	错误！未定义书签。
5.3	CHECK AND ADJUST AFTER CONNECTING THE POWER	错误！未定义书签。
6、	<b>CHECK BEFORE OPERATION</b> .....	错误！未定义书签。
7、	<b>DAILY OPERATION</b> .....	错误！未定义书签。
7.1	INPUT POWER TO OPERATE .....	错误！未定义书签。
7.2	CHECK AFTER OPERATION .....	错误！未定义书签。
7.3	COLLECT COINS AND KEEP RECORD .....	错误！未定义书签。
8、	<b>GAME SETTING</b> .....	错误！未定义书签。
8.1	KEYS FOR SETTING .....	错误！未定义书签。
8.2	SETTING METHOD .....	错误！未定义书签。
8.3	SETTING DESCRIPTION .....	错误！未定义书签。
9、	<b>ADJUSTMENT</b> .....	错误！未定义书签。
9.1	ADJUT THE COIN MECH .....	错误！未定义书签。
9.2	MAIN BOARD ADJUSTMENT .....	错误！未定义书签。
10、	<b>CHECK AND MAINTAIN</b> .....	错误！未定义书签。
10.1	DAILY CHEAK .....	20
10.2	DAILY MAINTAIN .....	20
11、	<b>TROUBLESHOOTING</b> .....	错误！未定义书签。
12、	<b>DIAGRAM FOR MAIN PARTS AND PARTS LIST</b> .....	错误！未定义书签。
12.1	BODT .....	错误！未定义书签。
12.2	STEERING WHEEL .....	错误！未定义书签。
12.3	CIRCUIT BOARD .....	错误！未定义书签。
12.4	COIN DOOR .....	错误！未定义书签。
12.5	CHASSIS .....	错误！未定义书签。
13、	<b>SCHEMATIC DIAGRAM</b> .....	错误！未定义书签。

## 1. Game introduction

Kiddie Pirate with unique, beautiful and comic appearance, interesting and exciting game, it is specially designed and developed by our company for the young people. It will be very essential and popular in amusement center.

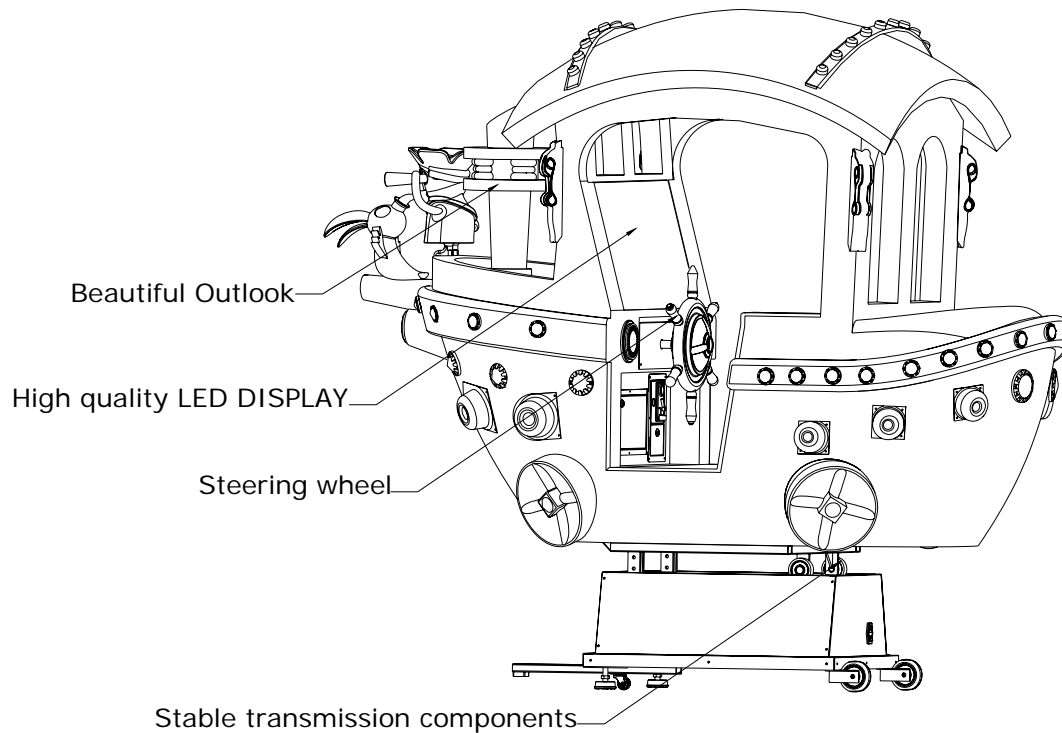

### Features:

Realistic, colorful, cutty outlook

Integrated main board, high-speed processing CPU, stable proformance.

High definition, high-quality LCD display.

Coin mech with high quality fits for various coins.

Simple, stimulating, strong operational sense and full of entertaining.

Operating income can be adjusted according to the situation.

## 2. Playing tips and Operations

### Playing tips:

Insert coin(s) after ride on the pirate ship. It moves up and down, forward and backward after a few seconds. The enemy ships will appear. Rotate the rudder or press the rudder up and down to aim the enemy ships and press the fire button to attack the enemy ships. The more enemy ships you hit, the high scores you get.

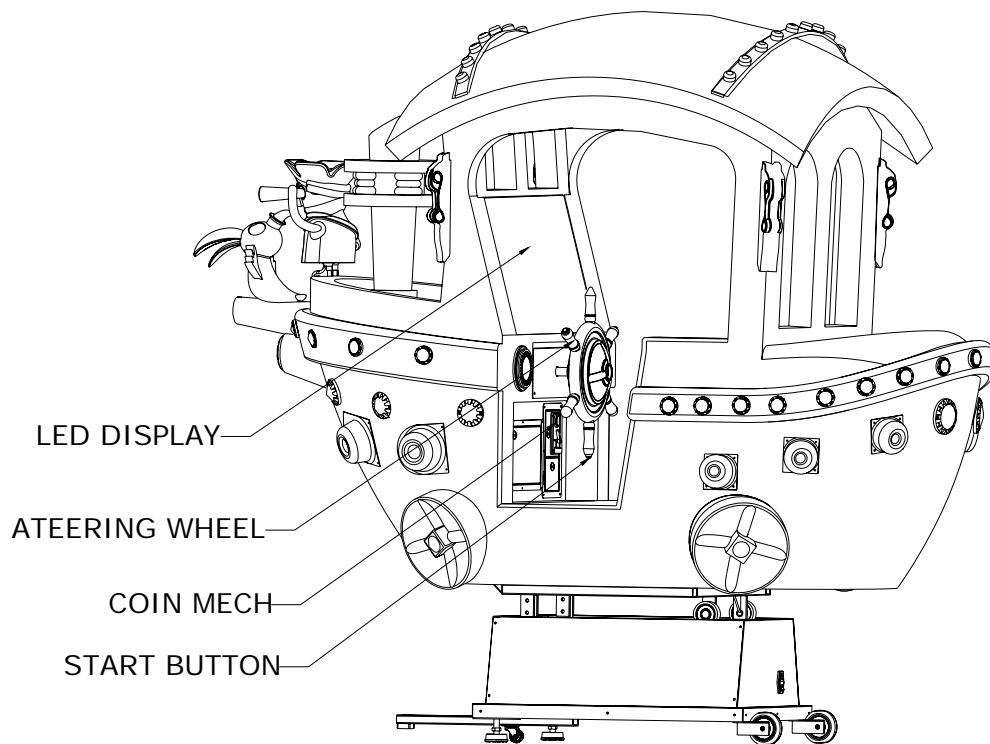

### 3. TECHNICAL PARAMETER

VOLTAGE: AC 220V/110V (50/60HZ)

MAX. CURRENT: 2.5A/5A

(Note: please refer to the nameplate located on the back of the game to check actual usage of voltage.)

MAX. POWER: 440W

COIN SIZE:  $\phi 21\text{mm} \sim \phi 30\text{mm}$  (diameter)

1.2mm ~ 2.5mm (thickness)





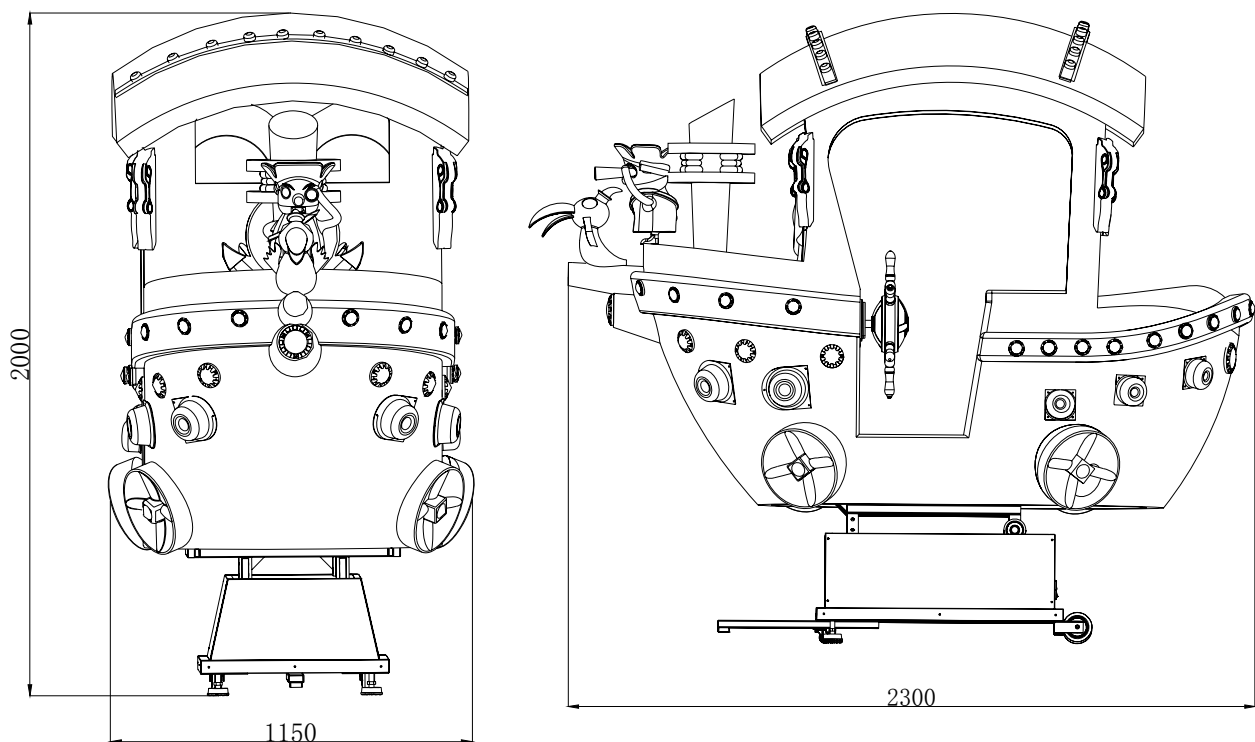

CAPACITY OF COIN BOX: 1200pcs of coins with coin size  $\phi 25\text{mm} * 1.5\text{mm}$

LOCATION REQUIRED:  $-5 \sim 40^{\circ}\text{C}$ , humidity is less than 90%. No contact with any corrosive liquid, no any greasiness and dirt.

DIMENSIONS: L2300mm\*1150mm\*H2000mm



Parts shipped with the game:

NO.	DRAWING	NAME	SPEC./MODEL	QTY
1		LED	Red , green, blue and yellow	Each2
2		Pull Pole		1
3		key	1285#	2
4		key	1396#	2
5		power cord		1
6		manual		1

## 4. Movement

Direction of movement diagram:

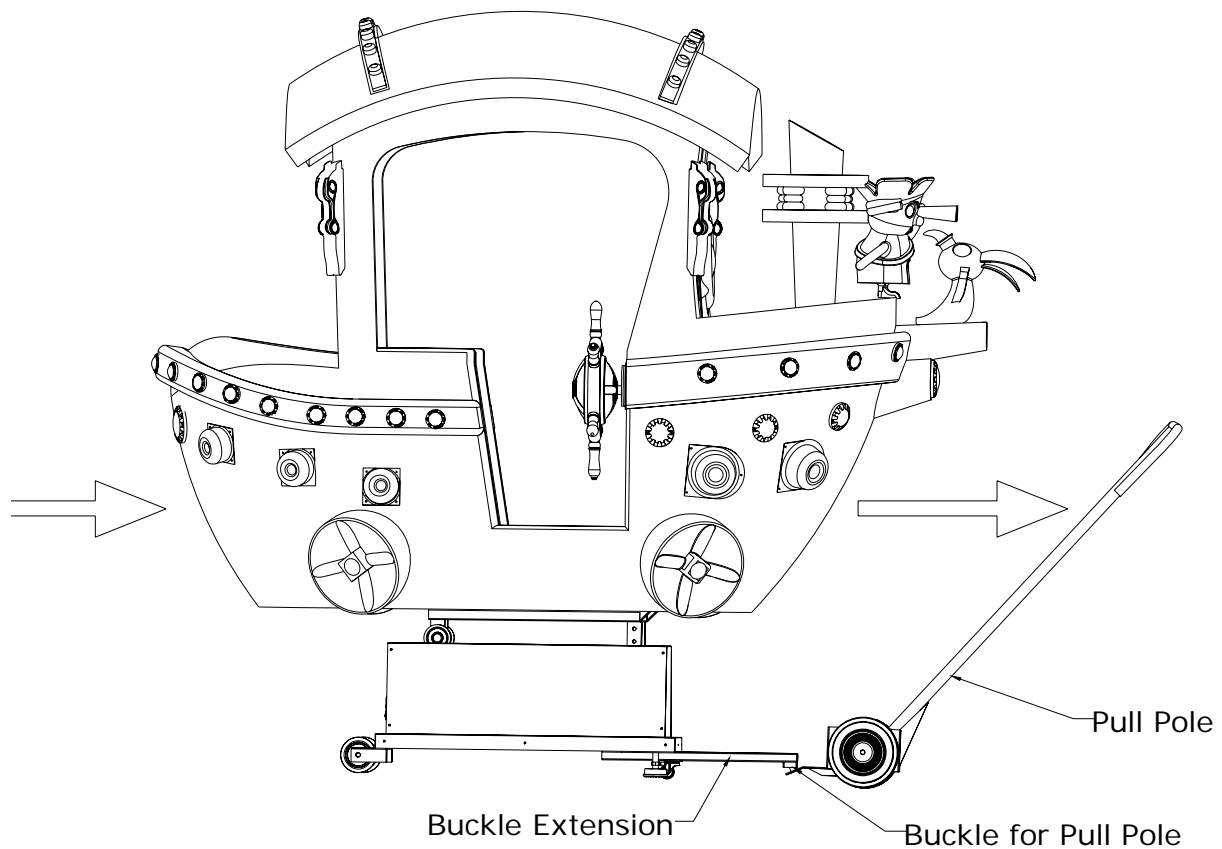

Insert the Pull Pole to the buckle and pressure the pull pole downward then the pirate ship move.

### WARNING

- Please power off the game first and pull out the cord, then move the game.
- Please do not carelessly move, turnover, transport the game; otherwise it will destroy the game.
- Prevent hitting, rubbing the games when move the games, otherwise it will damage the appearance of the game.

## 5. INSTALLATION

Please follow the direction below to install the game.

### 5.1 CHOOSE THE LOCATION FOR INSTALLATION

- 1) Put the Kiddie Pirate in the same type of Kiddie Ride with monitor then select the concrete placement machine according to the machine's exterior.
- 2) Choose the proper location for installation, please follow the below drawing to install.

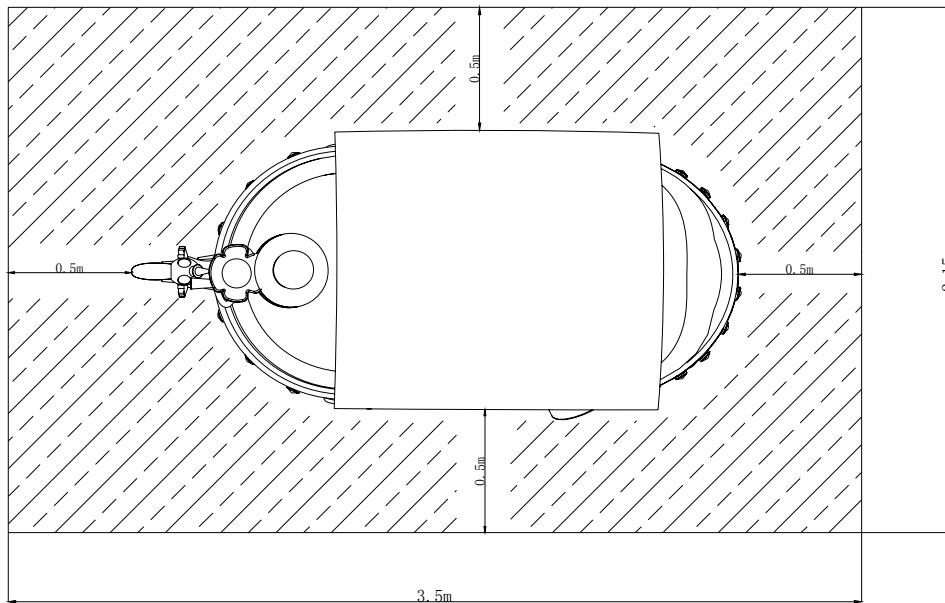

**WARNING:** It must be placed on the flat floor to make the machine on the ground steadily.

### 5.2 CHECK AND SET BEFORE CONNECTING THE POWER

- 1) Please check whether the parts of cabinet are loose caused by moving,

and the wire terminal should not drop out from the port.

- 2) Check whether the GND is connected.
- 3) Please check whether the resistance of power input at the both ends for GND is more than 100 megohm.
- 4) Connect the wires.

#### Attention

**A** Pleasemake sure the power cord is not pressed by wheel, foundation, etc. Otherwise, it will damage the wire to cause short circuit, even fire. Do not use strong power to extend and wring the wires. Do not make the wire be near to the high temperature object. Properly put the wire to avoid any kicking or treading.

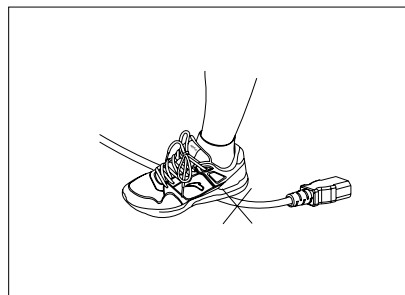
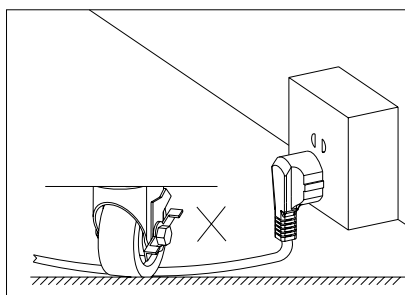

**B** Hold the plug to pull it out from the socket. Do not touch the plug with wet hands.

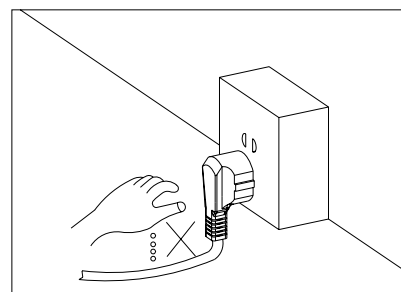
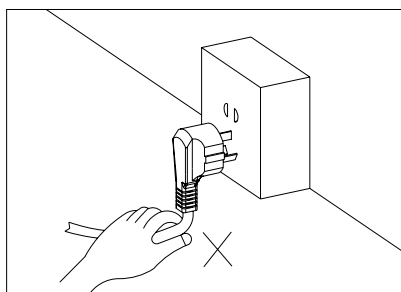

### 5.3 CHECK AND ADJUST AFTER CONNECTING THE POWER

- 1) Makesure the input voltageeissame asthe one stated on nameplateon

the back door of the game.

- 2) After connecting the power, please switch on the game.
- 3) Inserting coin to check if the coin machine can work properly.
- 4) Visually check the game and confirm the display and light can work properly.
- 5) Enter into the setting program and set the game settings (include coin, game time, game levels, etc.)
- 6) Insert coin to play the game, confirm the operation of the direction and the machine movement is normal
- 7) Check the sound if it is ok.

## **6、CHECK BEFORE OPERATION**

Check the game before operation to prevent the game from working improperly when operated.

Checking item:

- 1) Check if the cord is securely plugged in and without defects.
- 2) Check the location of game.
- 3) Check if the game case is without defects or burrs.
- 4) Check if the game without dirt and properly stuck on with marks

## **7、 DAILY OPERATION**

### **7.1 INPUT POWER TO OPERATE**

- 1) Turn on the machine power switch.
- 2) Visually check the game and confirm the display can work properly.
- 3) Check the sound if it is ok.
- 4) confirm the coin mech , operation of the direction and the machine movement is normal

Warning: Before operation, please confirm all the items above are ok.

### **7.2 CHECK AFTER OPERATION**

- 1) Check the display of the game and confirm it is proper.
- 2) Double check the coin mech, operation of the direction and the machine movement is normal, If it has any problems, please solve the problem as soon as possible.

### **7.3 COLLECT COINS AND KEEP RECORD**

Switch off the power and open the door of the coin box to take out the coins. Then open the door of the coin mech to keep a record of the coins' quantity.

## 8、 GAME SETTING

### 8.1 KEYS FOR SETTING

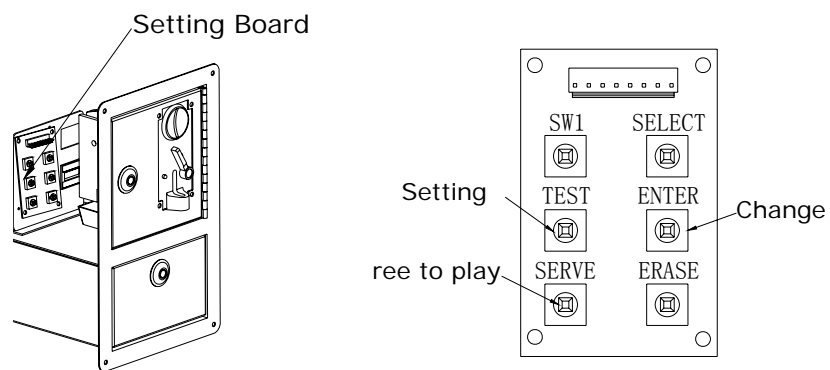

TEST: Enter into the setting menu or skip to the next menu.

ENTER: Change the setting.

SERVE: Free to play.

## 8.2 SETTING METHOD

Setting method: press“TEST”to enter into the game setting menu → press the “TEST” to choose the setting item →press “ENTER” to change the setting → press “ENTER” exit setting.

## 8.3 SETTING DESCRIPTION

### 1) Game setting interface:



Descriptions:

COIN: this setting can decide how many coins player should insert for one game.if setting to “2”,it means insert 2 coins for 1 game.

VOLUME: this setting can decide the volume and “1” stands for the lowest. (Note: the volume can be adjusted by adjusting the volume potentiometer on the amplifier board.).

TIME: this setting decides the limit time for one game. if setting to “3: 00”, it means has 3 minus for one game.

Steering wheel Test: This setting is to test whether the encoder is working noemally. When the steering wheel is turning, the number will change.

Language: This setting decides which language will be displayed in screen, Chinese or English.

## 2) Steering wheel Test

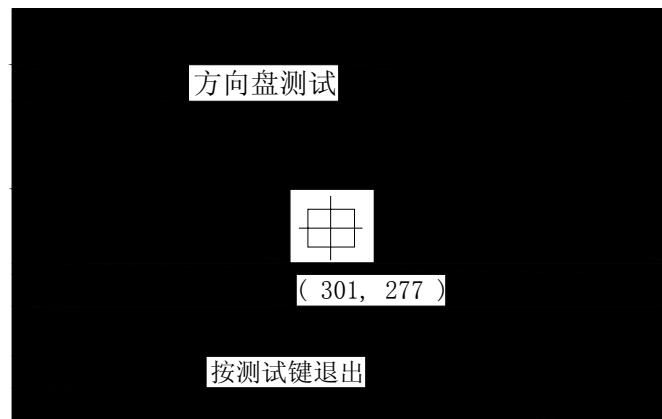

### Descriptions:

When the steering wheel is turning, the cursor will move in the horizontal direction.

When pressure downward or pull upward the steering wheel, the cursor will move in the vertical direction.

## 9. ADJUSTMENT

### 9.1 ADJUST THE COIN MECH

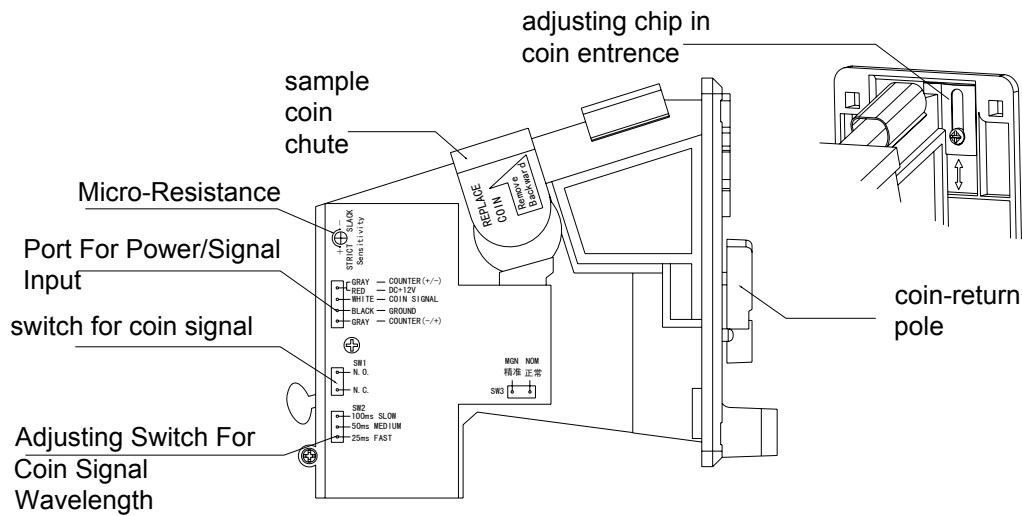

#### Descriptions:

- 1): Please take out the plastic coin from sample coin chute and replace it with token.
- 2): Remove the screws on back of coin entrance. Adjust the fixing chip on back of coin entrance according to the token's diameter, which prevents blocking the coin mech as inserting the large coin in by mistake.
- 3): Turn the COIN Switch to "NO" (COIN Signal wire and GND should be disconnected at usual time). Turning switch can be used as the coin mech switch when the game is power on.
- 4): Adjust the adjusting switch of COIN Signal wave length to 50MS.
- 5): Adjust the micro-adjusting resistance of token tolerance. Clockwise: increasing the sensitivity of token tolerance, that is, the range of accepting the token tolerance will be larger. Counterclockwise: decrease the sensitivity, that is, the range will be smaller and choose the token more strictly.

## 9.2 MAIN BOARD ADJUSTMENT

Diagram of main board:

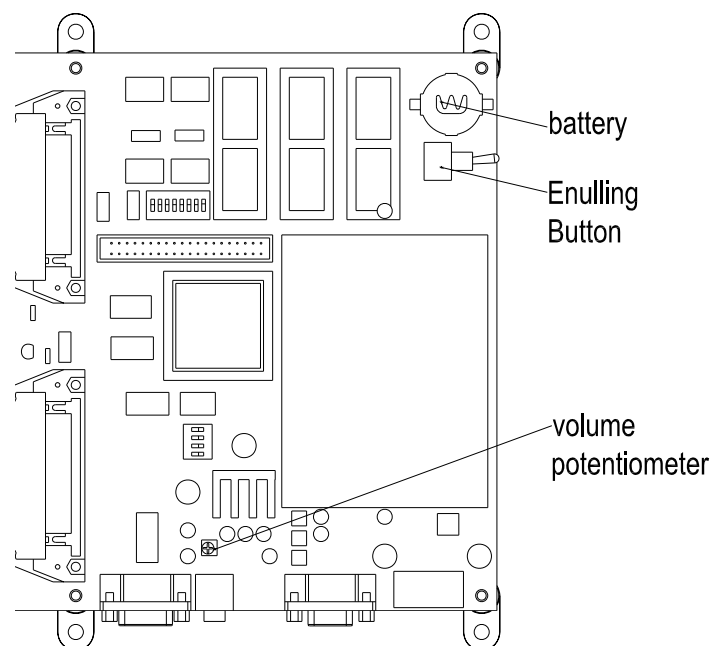

Descriptions:

**Enulling Button:** pressing this button can set the Game Setting to default and clear the data of Coin and Ticket saved in PCB.

**Volume Adjustment:** Use a flat screwdriver to twist the volume potentiometer to adjust the volume level of the machine. Turning clockwise will increase the volume; counterclockwise will decrease the volume.

### warning

The battery can save the data of game settings and coin number when the the power off. Please replace the battery when the machine can not save the game setting.

## 10、 CHECK AND MAINTAIN

! warning

Please check and maintain the game by technicians.

Please power off the game when check and maintain.

Please do not put any tools into cabinet, otherwise it will cause problem.

After checking, please tightly screw the screws and close the door.

### Dialy Check

ITEM	DESCRIPTION
COIN MECH	Check whether the coin mech canwork proper.
Potentiometer of the direction	Check whether the potentiometer of the direction can control the Kiddie Pirate's forward direction normally
sound	Check whether the sound and the volume are ok.
display	Check if the displayed colors are proper.
Temperature、humidity	Check if the temperature and humidity is proper

### Daily Maintenance

ITEM	DESCRIPTION
THE CABINET	Clean the cabinet with water and soft paper.
MONITOR	Clean the monitor with water and soft paper.
PCB	Sweep the dust and dirty in the board with small brush

## 11、 TROUBLESHOOTING

If you have any problem in installing or using the machine, we recommend that you first check the following table for possible cause of the problem and solution before asking for technical support.

PROBLEM	CAUSES	SOLUTIONS
Can not insert coin	no sample coin	insert sample coin
	Sensitivity for coin was adjusted too high	adjust the sensitivity
	coin mech is bad	replace the coin mech
Lights do not light up	The wire of light is loose.	Check the connection of light board.
	The light is bad.	Replace the light.
	The light's driver board is bad	Repair or replace the driver board.
Have no movement	The connection of wire is bad.	Properly reconnect the wires of motor.
	The inverter is bad	Repair or replace the inverter
	The motor capacitor is bad	Replace the motor capacitor
	Motor is bad	Replace the AC motor
Steering wheel failure	direction encoder circuit is bad	connect the encoder circuit
	direction encoder is bad	replace the direction encoder
Have no display.	the monitor power line is loose	reconnect the monitor power line
	Monitor signal cable was not connected	reconnect the monitor signal cable
	the monitor is bad	replace the monitor
	The main board is bad.	Replace the main board.
Have no sound	The speaker is bad.	Check and replace the speaker.
	The wire of sound signal is loose.	Check the connection of sound signal.
	The volume is too low.	Adjust the resistor VR1102 on main board to increase the volume.
No movement after powering on the game	No AC110V/220V input	Check the connection
	The fuse is burnt.	Replace the fuse.
	No output voltage of power supply.	Repair or replace the power supply.
	The main board is bad.	Replace the main board.

## 12. DIAGRAM FOR MAIN PARTS AND PARTS LIST

### 12.1 Pirate Ship Body

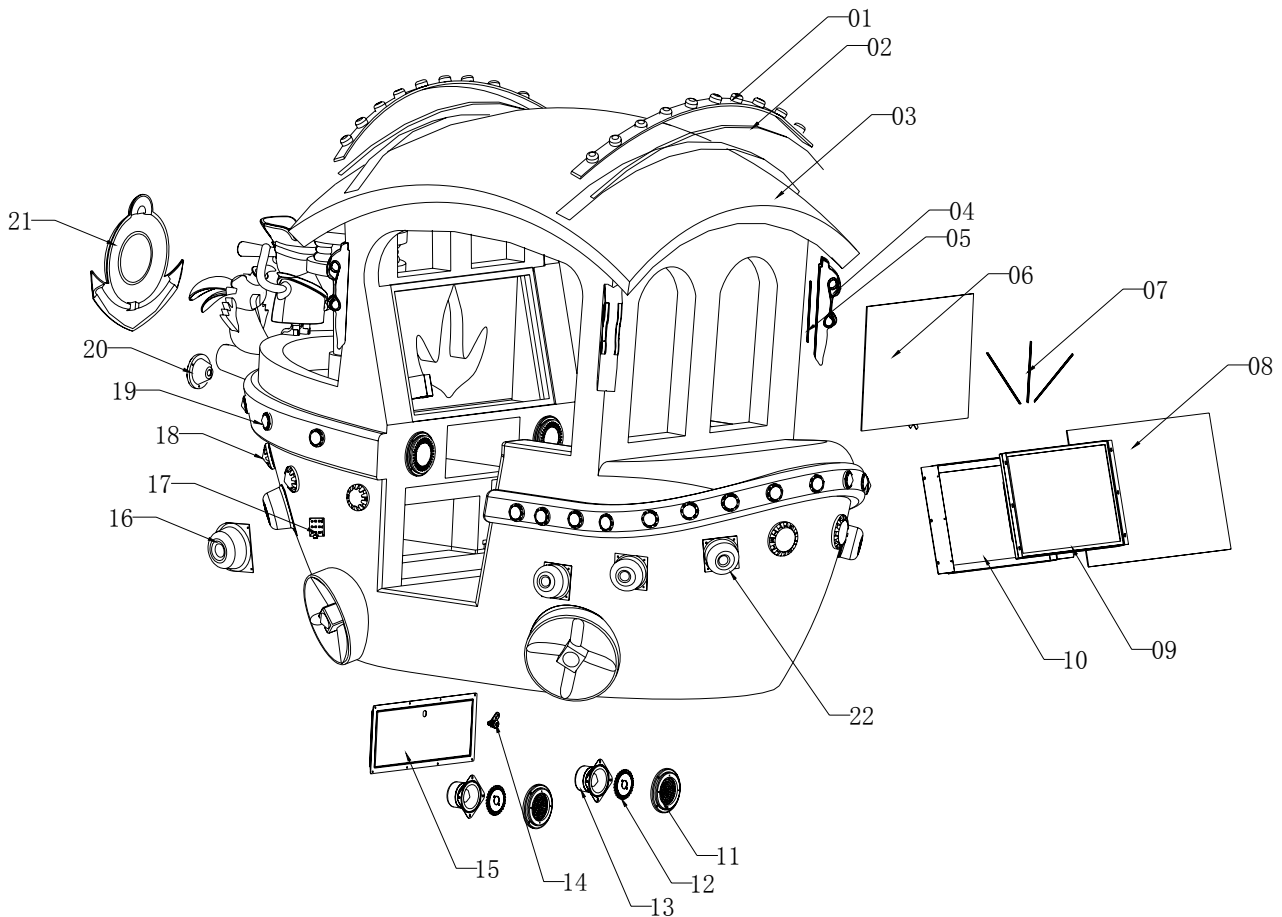

NO.	NAME	QTY
01	lampshade for flashing light strip	2
02	colored lights strip	2m
03	fiberglass body	2
04	lampshade for pillar light	4
05	colored lights strip	1. 2m
06	light strip fittings	1
07	colored lights strip	0. 5m
08	cover for monitor	1
09	monitor 19"	1
10	display frame	1
11	ABS for speaker	4

NO.	NAME	QTY
12	flash light board for speaker	4
13	speaker	4
14	lock 1285	1
15	maintenance door	1
16	large lampshade	4
17	flash light board	10
18	middle LED light	6
19	small LED light	26
20	large LED light	3
21	ABS Cover of Anchor	1
22	middle light cover	6

## 12.2 Steering wheel

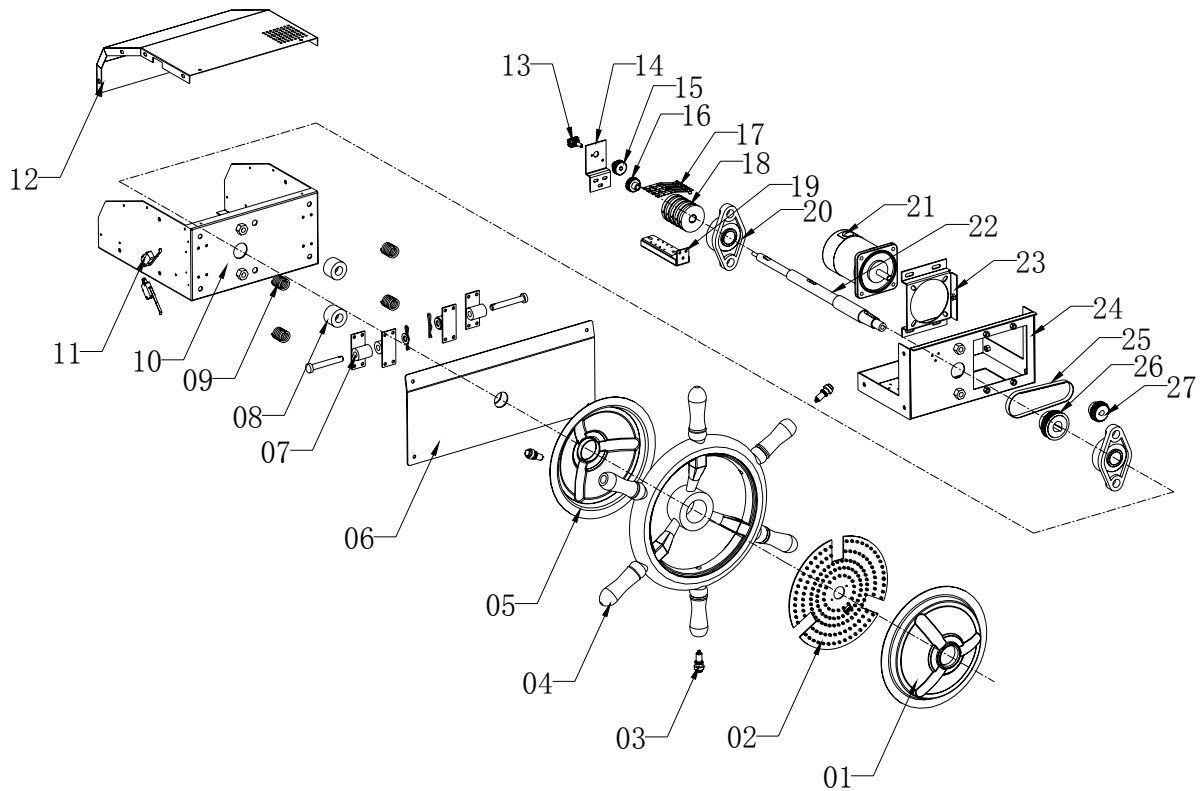

NO.	NAME	QTY
01	steering wheel cover (front)	1
02	flash light board for steering wheel	1
03	button	3
04	steering wheel	1
05	steering wheel cover (rear)	1
06	panel	1
07	fixing housing	4
08	bounding housing	2
09	spring	4
10	bounding box	1
11	long micro switch	2
12	cover	1
13	encoder	1
14	coder fixed	1

NO.	NAME	QTY
15	gear	1
16	gear	1
17	Carbon brush piece	4
18	conductive ring	4
19	conductive ring fittings	1
20	pillow block bearing	2
21	DC motor 24V	1
22	principal axis	1
23	motor fitting board	1
24	interior casing	1
25	synchronous pulley	1
26	head pulley	1
27	driven pulley	1

## 12.3 Circuit Board

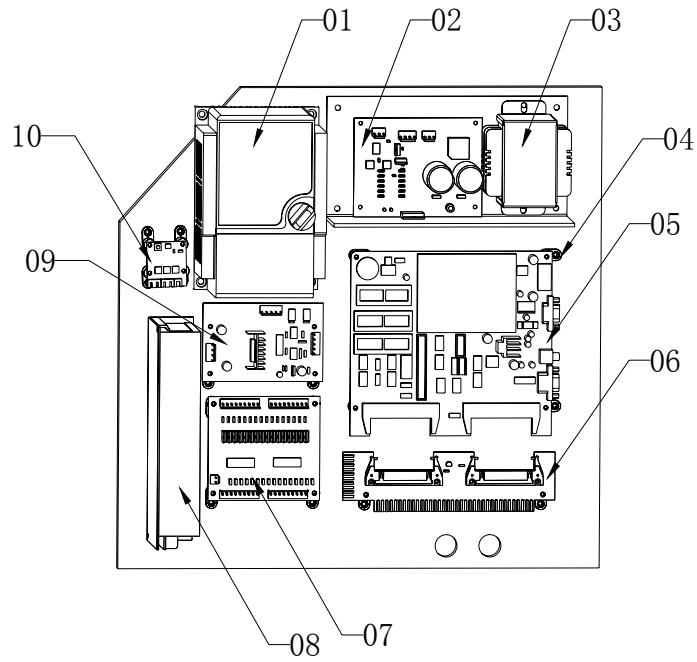

NO.	NAME	QTY
01	converter	1
02	power amplifier board	1
03	transformers 110V/18V 80W	1
04	PCB pin	16
05	main board	1
06	Signal interface board	1

NO.	NAME	QTY
07	flash light signal amplifier board	1
08	power box 5V 3A	1
09	motor driven board	1
10	light driven board	1

## 12.4 Coin door

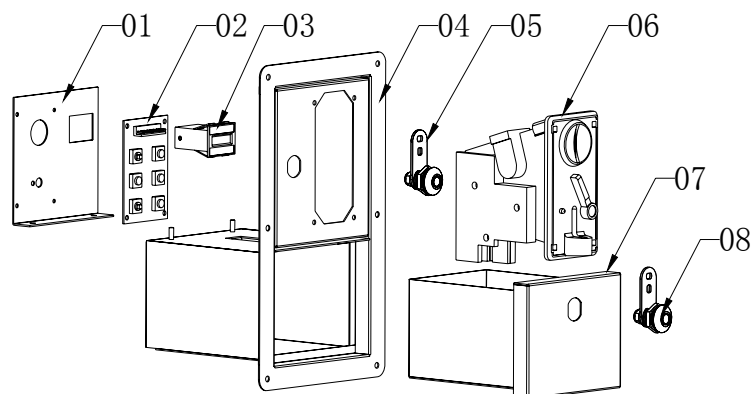

NO.	NAME	QTY
01	setting board fitting	1
02	setting board	1
03	coin meter	1
04	coin door	1
05	lock 1285	1
06	coin mech	1

NO.	NAME	QTY
07	coin box	1
08	lock 1396	1

## 12.5 Chassis

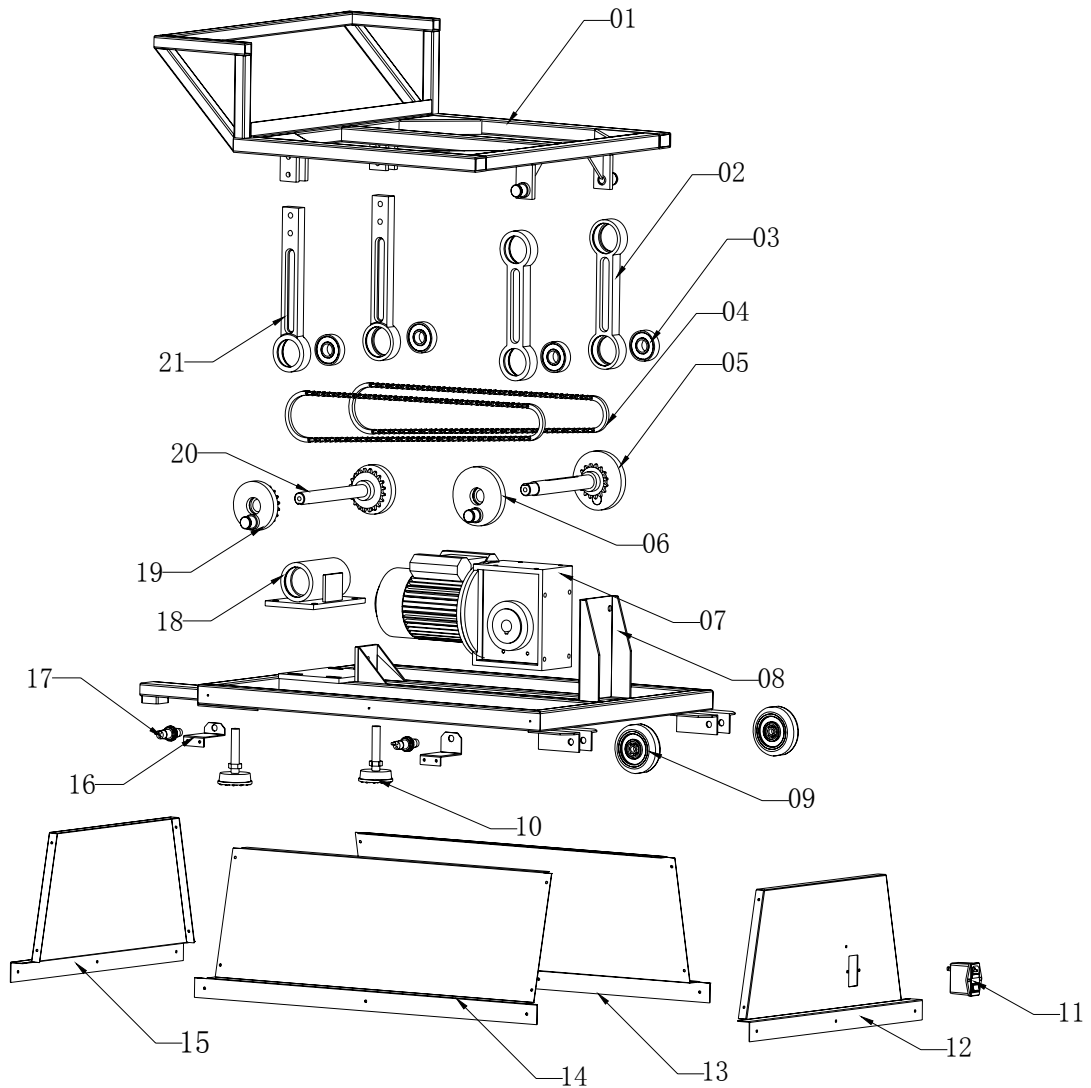

NO.	NAME	QTY
01	body bracket	1
02	cam bracket 2	2
03	deep groove ball bearing	8
04	chain	2
05	automatic eccentricB	1
06	automatic eccentricA	1
07	Three-phase AC motor	1
08	base component	1
09	fixed wheel	2
10	fixed foundation	2
11	power filter	1

NO.	NAME	QTY
12	rear side board	1
13	right side board	1
14	left side board	1
15	front side board	1
16	sensor mounting plate	2
17	proximity switch	2
18	driven bearing housing	1
19	driven eccentricB	1
20	driven eccentricA	1
21	cam bracket 1	2

# 13、 SCHEMATIC

## DIAGRAM

